

DC POWER SUPPLY

GPR-SUPER SERIES

(ANALOG/DIGITAL TYPE)

CONTENTS

SECTION	PAGE
1 INTRODUCTION	1
2. SPECIFICATIONS	1
2-1 General	1
2-2 Constant Voltage Operation	3
2-3 Constant Current Operation	3
2-4 Indicator Meter	3
2-5 Insulation	4
3. THEORY OF OPERATION	4
4. PANEL CONTROLS AND INDICATORS	8
4-1 Front Panel	8
4-2 Rear Panel	8
5. OPERATION INSTRUCTIONS	12
5-1 Precaution	12
5-2 Setting Current Limit	12
5-3 Constant Voltage/Constant Current Characteristic	12
6. MAINTANCE	14
6-1 Adjustment	14
6-2 Low Voltage Model	14
6-3 High Voltage Model	15

1. INTRODUCTION

The regulated DC power supply have been designed to provide the most often required in the laboratory, schools and production lines.

The output voltage is continuously adjustable between 0 to rating voltage in one range by means of a coarse and fine potentionmeter, the load current may have any value from 0 to rating current and adjusted by means of a coarse and fine potentionmeter. Both outputs can accurately read on voltmeter and ammeter.

Both stability and ripple are extremely good to meet the requirements of modern circuit design. The unit can be used as either constant voltage or current source. The various operation mode are described in more detail in the Operation Instruction section.

Application for Material and Products Aging.

Built-in Overvoltage and Overcurrent tripped crowbar.

2. SPECIFICATIONS

2-1 General

Main supply

AC 120V +/- 10% 50/60 Hz (otherwise by order made)

Rating, dimension and weight

See Table 2-1

Operation mode

Series Operation

Operation Temperature & Humidity

0°C to 40°C, <80%

Storage Temperature & Humidity

-10°C to 70°C, <70%

Accessories

Test Lead GTL-104 (current $\leq 10A$) x1
or GTL-105 (current $\leq 4A$)

Notes: Current > 10A or vottage > 600V without Test Lead.

Operation Manual.....x1

Table 2-1

MODEL	Max. Rating		Dimensions	Weight
	Volts (V)	Amps (A)	WxHxD (m/m)	Kg
GPR-100H05	1000	0.5	430 (W) 178 (H) 572 (D)	28.5
GPR-60H15	600	1.5		30.5
GPR-50H15	500	1.5		29.5
GPR-35H20	350	2		29.5
GPR-25H30	250	3		29.5
GPR-16H50	160	5		30.5
GPR-11H50	110	5		28.5
GPR-7510H	75	10		29.5
GPR-6015H	60	15		30.0
GPR-3520H	35	20		29.5
GPR-1850H	18	50		30.0
GPR-1830H	18	30		28.5
GPR-0875H	8	75		29.0

(NOTE: All model with digital display available.)

2-2 Constant Voltage Operation

- (1) Output voltage ranges 0 to rating voltage continuously adjustable.
- (2) Voltage regulation
line regulation $\leq 0.01\%+3\text{mV}$
load regulation $\leq 0.01\%+5\text{mV}$
load regulation $\leq 0.02\%+5\text{mV}$ ($\geq 10\text{A}$)
- (3) Recovery time $\leq 100\mu\text{s}$ (50% Load change, Minimum load 0.5A)
- (4) Ripple & Noise $\leq 2\text{mV rms}$ (5Hz ~ 1MHz)
- (5) Temperature coefficient $\leq 300 \text{PPM}/^\circ\text{C}$
- (6) OVP setting ranges from 15% to 105% of rate voltage continuously adjustable

2-3 Constant Current Operation

- (1) Output current ranges 0 to rating current continuously adjustable.
- (2) Current regulation
line regulation $\leq 0.2\%+3\text{mA}$
load regulation $\leq 0.2\%+5\text{mA}$
- (3) Ripple current $\leq 5\text{mA rms}$ ($\leq 20\text{A}$)
 $\leq 20\text{mA rms}$ ($\leq 50\text{A}$)
 $\leq 100\text{mA rms}$ ($\leq 100\text{A}$)

2-4 Indicator Meter

- (1) Digital Type
Display : 3½ Digits 0.5" Red LED Display.
Accuracy : $\pm (0.5\% \text{ of rdg} + 2 \text{ digits})$
Voltage range : 19.99V of full scale (rating voltage $\leq 18\text{V}$).
199.9V of full scale (rating voltage $\leq 180\text{V}$).
1999V of full scale (rating voltage $\leq 1800\text{V}$).
Current range : 1.999A of full scale (rating current $\leq 1.8\text{A}$).
19.99A of full scale (rating current $\leq 18\text{A}$).
199.9A of full scale (rating current $\leq 180\text{A}$).

- (2) Analog Type
Meter: Voltmeter and Ammeter each one
Class: 2.5
Dimensions: 60 x 80 m/m

2-5 Insulation

- Between chassis and output terminal
100M Ω or above (DC 1000V)
Between chassis and AC card
100M Ω or above (DC 1000V)

3. THEORY OF OPERATION

3-1 Low Voltage Circuit (FIG. 1)

The power supply consists of an AC input circuit and transformer, a bias supply consisting of a rectifier and filter and reference voltage source, a main regulator circuit consisting of the main rectifier and filter, a series regulator, a current comparator, a voltage comparator, a reference voltage amplifier, tag a instant over load protection circuit and relay control circuit.

The circuit element are several of integrated circuit (U201-U205, U101).

The circuit is discussed with reference to the block diagram Function Description.

Single phase input power is applied to transformer through the input circuit.

Auxiliary rectifier D101-D104 provides a bias voltage filtered by capacitor C101-C104 for the preregulator U101, Q101, Q102, that provides a regulator voltage for element of action.

The main rectifier, a full wave bridge rectifier, provides the power which is filtered by capacitor C401-C408 and then regulated via a series regulator and deliver to the output.

U204 provides a reference for U205, U205 acted as a current limiter. When current is over predominate rating, it acted and decreased the current. U201 provides a reference voltage for U202, U202 is a inverter amplifier, U203 is a comparator amplifier. It's may be made comparator for reference voltage and detector feedback voltage, and then deliver to Q203 this time output voltage is calibrated.

Q201 is instant over load protection circuit, Q201 turn on when voice response load adds at instant. It controls Q203 current magnitude of Ib makes output current limited.

The output voltage is controlled by the output switch.

The relay control circuit provides limited power dissipation in series regulator.

3-2 High Voltage Circuit (FIG. 2)

The power supply consists of an AC input circuit and transformer, a bias supply consisting of a rectifier and filter and reference voltage source, a main regulator circuit consisting of the main rectifier and filter, a series regulator, a current comparator, a voltage comparator, a reference voltage amplifier and a transistor driver consisting of rectifier and filter.

The circuit element are several of integrated circuit (U201-U205, U101).

The circuit is discussed with reference to the block diagram Function Description.

Single phase input power is applied to transformer through the input circuit.

Auxiliary rectifier D101-D104 provides a bias voltage filtered by capacitor C101-C104 for the preregulator U101, Q101, Q102, that provides a regulator voltage for element of action.

The bias voltage is provides by auxiliary rectifier (D302 ~ D305) to turn the transistor (Q303 ~ Qn) on.

The main rectifier is make by rectifiers and filters and then regulated via a series regulator and deliver to the output.

U204 provides a reference voltage for U205, U205 acted as a current limiter. When current is over predominate rating, it acted and decreased the current. U201 provides a reference voltage for U202, U202 is a inverter amplifier, U205 is a comparator amplifier. It's may be made comparator for reference voltage and detector feedback voltage, and then deliver to Q202, Q203 this time output voltage is calibrated.

The output voltage is controlled by the output switch.

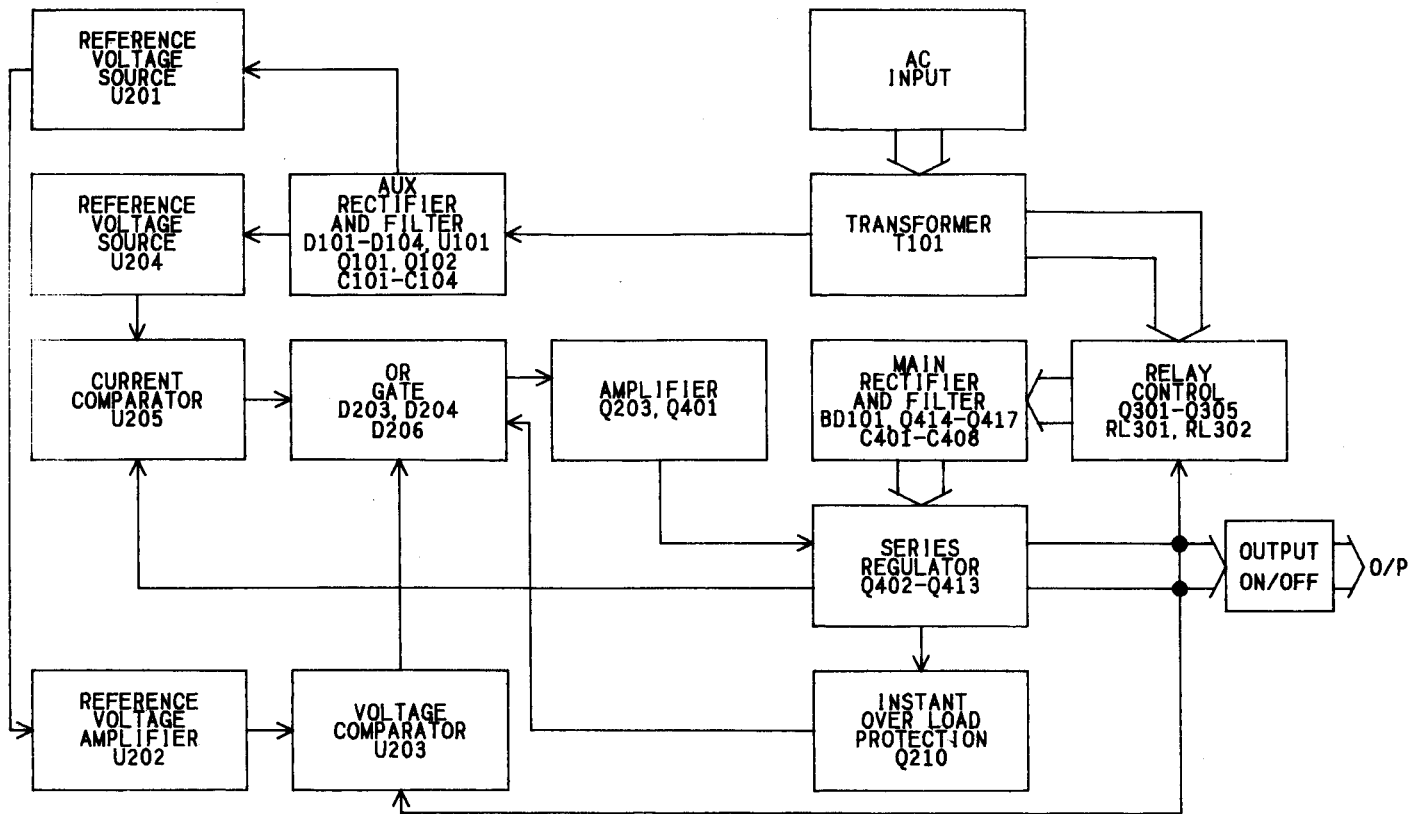

Fig. 1 Block Diagram (Less Than 100V)

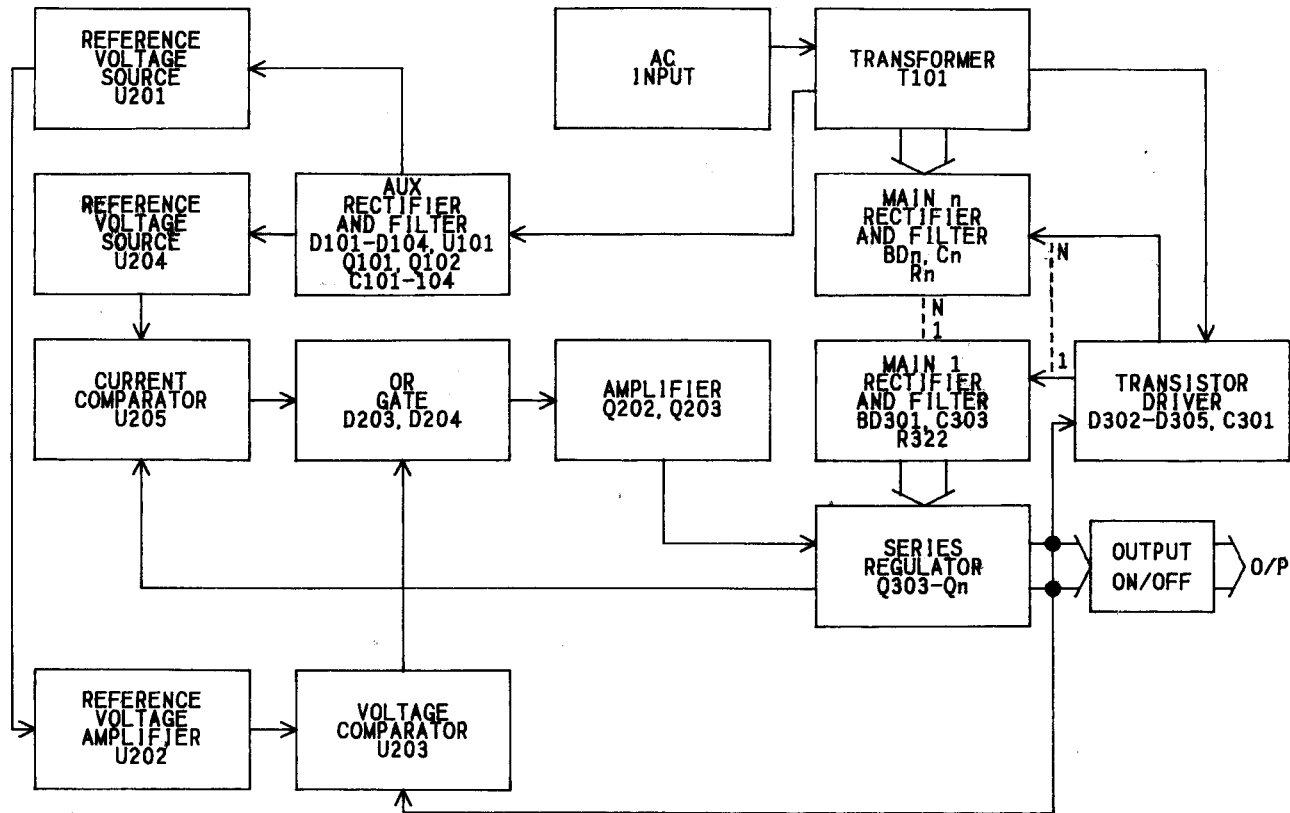

Fig. 2 Block Diagram (More Than 100V)

4 PANEL CONTROL AND INDICATORS

4-1 Front panel (FIG. 4-1, 4-2)

1. CV indicator lights when the power turn on and constant voltage operation.
2. CC indicator lights when this unit in constant current operation.
3. Voltage for the voltage adjustment of the output voltage.
4. Current for the current adjustment of the output current.
5. "+" output terminal positive polarity, load current. (Red)
6. GND terminal Earth and chassis ground. (Green)
7. "-" output terminal negative polarity, load current. (Black)
8. Voltmeter indicates the output voltage. (Digital panel meter or Analog meter)
9. Ammeter indicates the output current. (Digital panel meter or Analog meter)
10. Power control on/off switch with overvoltage and overcurrent tripped crowbar.
11. Current limit switch when the current limit switch is pushed, the Ammeter indicates the value of current limit setting.
12. O.V.P. switch when the O.V.P. switch is pushed, the Voltmeter indicates the value of over voltage protection setting.
13. O.V.P. adjust for the O.V.P. adjustment of the over voltage protection setting value.
14. Output switch the output voltage is controlled by the output switch.
15. Output indicator lights when the output switch turn on.
16. Caution high voltage the symbol on the front panel denotes that a potential of 100V or more may be present on the terminals.

WARNING : Dangerous voltages to avoid electrical shock, do not touched the output terminal, after power on.

4-2 Rear panel (FIG. 4-3)

17. "L" terminal AC. live input terminal.
18. "N" terminal AC. neutral input terminal.
19. GND terminal Earth and chassis ground.
20. Cooling fan Ventilates the hot air out, to prevent output stage from thermo shock, and also improves the temperature coefficient.
21. "S-" terminal Negative polarity sense terminal.
22. "-" terminal Negative polarity output terminal.
23. "+" terminal Positive polarity output terminal.
24. "S+" terminal Positive polarity sense terminal.
25. GND terminal Earth and chassis ground.

NOTE: If the load current great than "10A", then the "21" ~ "25" terminal must be used, and the output connected from front panel change to the rear panel.

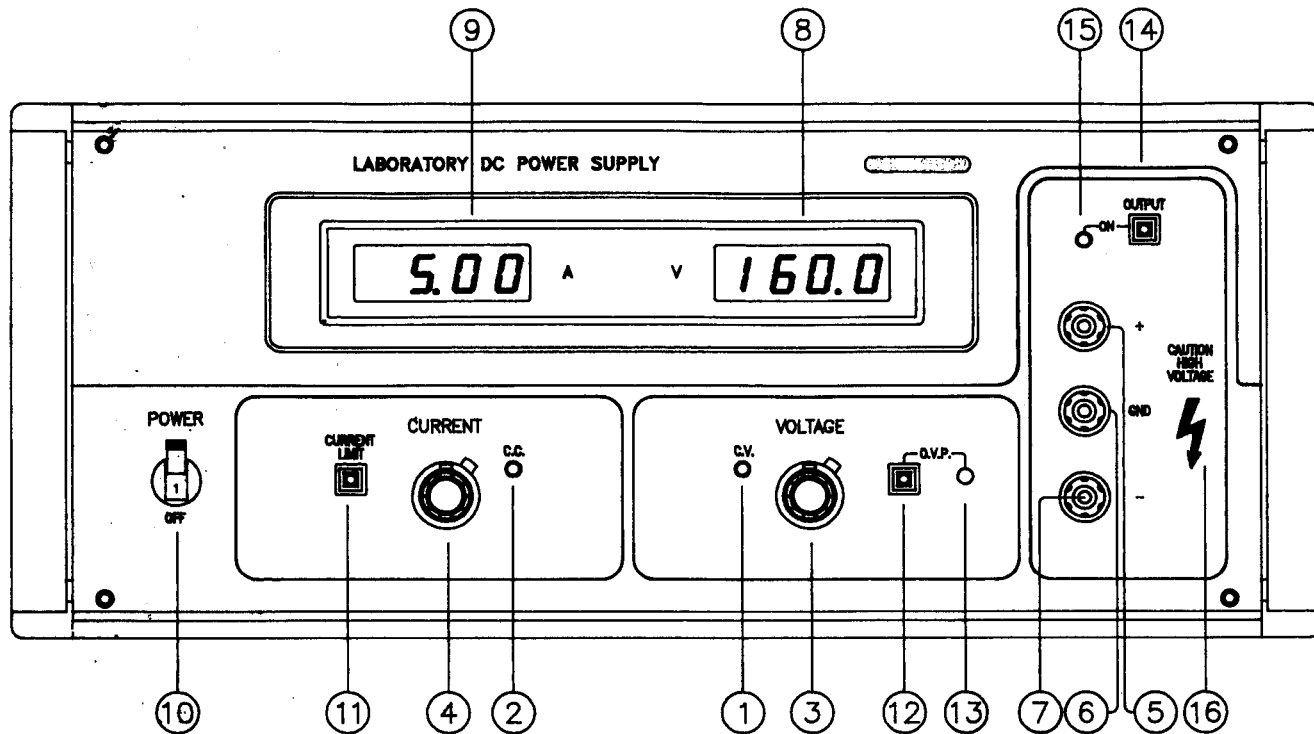

Fig. 4-1 Front Panel (Digital Type)

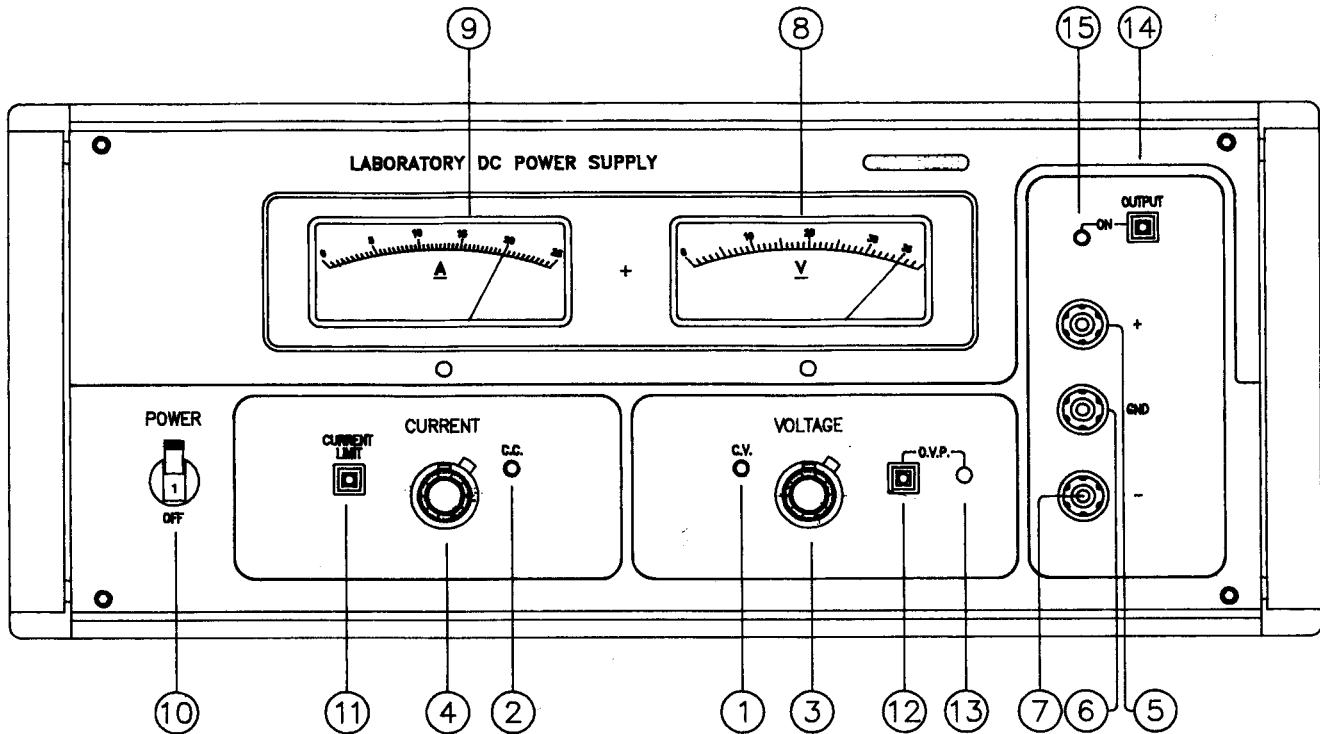
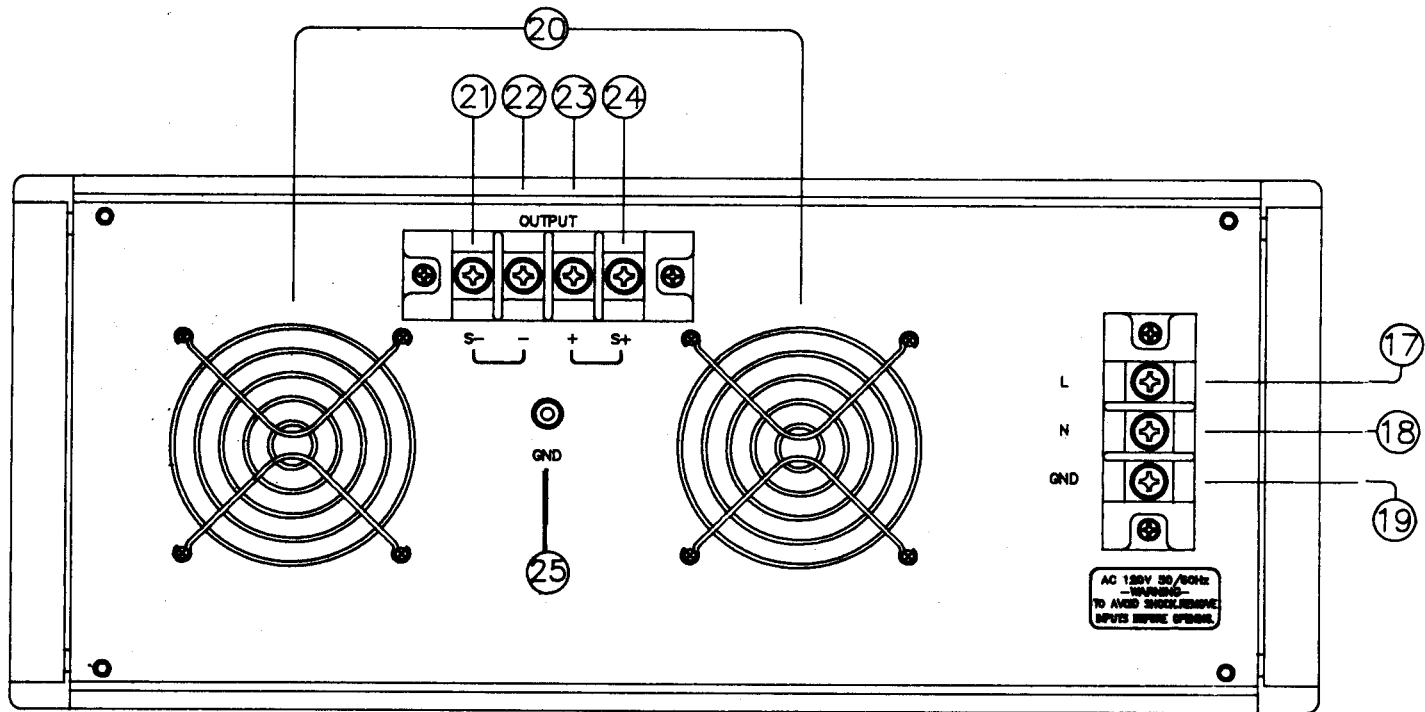

Fig. 4-2 Front Panel (Analog Type)



5. OPERATION INSTRUCTIONS

5-1 Precaution

- (1) AC input
AC input should be within the range of line voltage $\pm 10\%$ 50/60Hz.
- (2) Installation
Avoid using the supply in a place where the ambient temperature exceeds 40°C . The heat sink located at the rear of the supply must have sufficient air space for radiation.
- (3) Output voltage overshoot
Voltage between output terminals never exceeds the preset value when the power is turned on or off.

5-2 Setting Current Limit

- (1) Determine the maximum safe current for the device to be powered.
- (2) Depressed the current limit switch.
- (3) Rotate the COARSE VOLTAGE control away from zero sufficiently for the CC indicator to light.
- (4) Adjust the CURRENT control for the desired current limit. Read the current value on the Ammeter.
- (5) The current limit (overload protection) has now been preset. Do not change the CURRENT control setting after this step.
- (6) Release the current limit switch.

5-3 Constant Voltage/Constant Current Characteristic

The working characteristic of this series Power Supplies is called a constant voltage/constant current automatic crossover type. This permits continuous transition from constant current to constant voltage modes in response to the load change. The intersection of constant voltage and constant current modes is called the crossover point. Fig. 5-1 shows the relationship between this crossover point and the load.

For example, if the load is such that the power supply is operating in the constant voltage mode, a regulated output voltage is provided. The output voltage remains constant as the load increases, up until the point where the preset current limit is reached. At that point, the output current becomes constant and the output voltage drops in proportion to further

increases in load. The crossover point is indicated by the front panel LED indicators. The crossover point is reached when the CV indicator goes off and the CC indicator comes on.

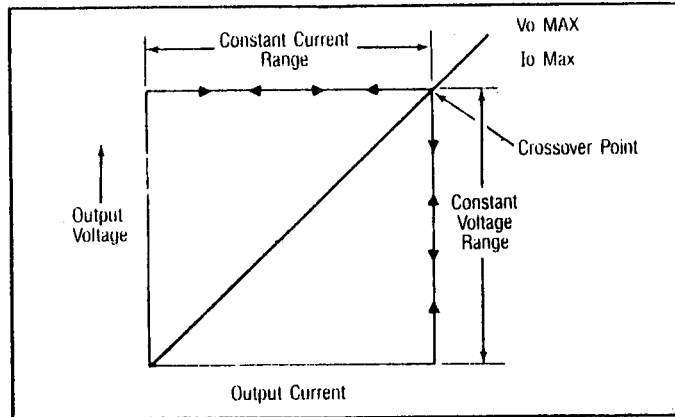

Fig. 5-1 Constant Voltage/Constant Current Characteristic.

Similarly, crossover from the constant current to the constant voltage mode automatically occurs from a decrease in load. A good example of this would be seen when charging a 12-volt battery. Initially, the open circuit voltage of the power supply may be preset for 13.8 volts. A low battery will place a heavy load on the supply and it will operate in the constant current mode, which may be adjusted for a 1 amp charging rate. As the battery becomes charged, and its voltage approaches 13.8 volts, its load decreases to the point where it no longer demands the full 1 amp charging rate. This is the crossover point where the power supply goes into the constant voltage mode.

6. MAINTENANCE

WARNING : Be sure to wear rubber insulating gloves whenever operation this Tester, in order to guard against electric shock hazards.

The following instructions are for use by qualified personnel only. To avoid electrical shock, do not perform any servicing other than contained in the operating instructions unless you are qualified to do so.

6-1 Adjustments

This unit was accurately adjusted at the factory before shipment. Readjustment is recommended only if repairs have been made in a circuit affecting adjustment accuracy, or if you have a reason to believe the unit is out of adjustment. However, adjustments should be attempted only if a multimeter with an accuracy of $\pm 0.1\%$ DCV or better is available (GOOD WILL Model GDM-8135 or equivalent).

6-2 Low Voltage Model (Less than 100V)

If readjustment is required, use the following procedure. Locations of the adjustments are shown in FIG. 6-1 and FIG. 6-2.

(1) Adjustment Of The Rating Voltage

- A. Adjust O.V.P. trimmer pot VR203 (Front Panel) controls to maximum.
- B. Connect an accurate ($\pm 0.1\%$) external multimeter to measure the dc voltage at output terminals of the power supply.
- C. Set the VOLTAGE controls to minimum. (fully counterclockwise).
- D. Adjust trimmer pot VR204 for a reading of 0 volts on the multimeter.
- E. Turn the VOLTAGE controls to maximum. (fully clockwise)
- F. Adjust trimmer pot VR201 for a reading of rate volts $\times 1.05$ on the multimeter.
- G. Set the VOLTAGE controls for a reading of rate volts on the multimeter.
- H. Adjust trimmer pot VR209 (VR201 digital type) for a reading of rate volts on the voltmeter (Digital panel meter, digital type) of the power supply.

- J. When the switch of over voltage protection is depressed as follow K step.
 - K. Adjust O.V.P. trimmer pot VR203 (Front Panel) for a reading of rate volts x 1.05 on the multimeter.
 - L. Release the switch of over voltage protection.
- (2) Adjustment of the rating current
- A. Set the VOLTAGE controls to 5V.
 - B. Set the CURRENT controls to minimum. (fully counterclockwise)
 - C. Adjust VR211 until the C.C. indicator first lights.
 - D. Connect the external multimeter to measure dc current at the output terminals of the power supply.
 - E. Setting and turn the CURRENT controls to maximum. (fully clockwise)
 - F. Adjust trimmer pot VR205 for a reading of rate amps x 1.05 on the multimeter.
 - G. Readjust the CURRENT control for a reading of rate Amps on the multimeter.
 - H. Adjust trimmer pot VR210 (VR202 digital type) to calibrate the Ammeter (digital panel meter, digital type) of the power supply for the same reading as the multimeter.
 - I. Set the CURRENT controls to minimum. (fully counterclockwise)
 - J. When the current limit switch is depressed as follow K step and M step.
 - K. Adjust trimmer pot VR212 for a reading of 0 amps on the Ammeter (Digital panel meter, digital type) of the power supply.
 - L. Readjust the CURRENT control for a reading of rate Amps on the multimeter.
 - M. Adjust trimmer pot VR208 to calibrate the Ammeter (digital panel meter, digital type) of the power supply for the same reading as the multimeter.
 - N. Release the current limit switch.

6-3 High Voltage Model (More then 100V)

If readjustment is required, use the following procedure. Locations of the adjustments are shown in FIG. 6-1 and FIG. 6-3.

(1) Adjustment Of The Rating Voltage

- A. Adjust O.V.P. trimmer pot VR203 (Front Panel) controls to maximum.
- B. Connect an accurate ($\pm 0.1\%$) external multimeter to measure the dc voltage at output terminals of the power supply.

- C. Set the VOLTAGE controls to minimum. (fully counterclockwise)
- D. Adjust trimmer pot VR204 for a reading of 0 volts on the multimeter.
- E. Turn the VOLTAGE controls to maximum. (fully clockwise)
- F. Adjust trimmer pot VR201 for a reading of rate volts $\times 1.05$ on the multimeter.
- G. Set the VOLTAGE controls for a reading of rate volts on the multimeter.
- H. Adjust trimmer pot VR209 (VR201 digital type) for a reading of rate volts on the voltmeter (Digital panel meter, digital type) of the power supply.
- J. When the switch of over voltage protection is depressed as follow K step.
- K. Adjust O.V.P. trimmer pot VR203 (Front Panel) for a reading of rate volts $\times 1.05$ on the multimeter.
- L. Release the switch of over voltage protection.

(2) Adjustment of the rating current

- A. Set the VOLTAGE controls to 5V.
- B. Set the CURRENT controls to minimum. (fully counterclockwise)
- C. Adjust VR211 until the C.C. indicator first lights.
- D. Connect the external multimeter to measure dc current at the output terminals of the power supply.
- E. Setting and turn the CURRENT controls to maximum. (fully clockwise)
- F. Adjust trimmer pot VR205 for a reading of rate Amps $\times 1.05$ on the multimeter.
- G. Readjust the CURRENT control for a reading of rate amps on the multimeter.
- H. Adjust trimmer pot VR210 (VR202 digital type) to calibrate the Ammeter (digital panel meter, digital type) of the power supply for the same reading as the multimeter.
- I. Set the CURRENT controls to minimum. (fully counterclockwise)
- J. When the current limit switch is depressed as follow K step and M step.
- K. Adjust trimmer pot VR212 for a reading of 0 amps on the Ammeter (digital panel meter, digital type) of the power supply.
- L. Readjust the CURRENT control for a reading of rate Amps on the multimeter.
- M. Adjust trimmer pot VR207 to calibrate the Ammeter (digital panel meter, digital type) of the power supply for the same reading as the multimeter.
- N. Release the current limit switch.

PM-514A
PM-514A-1

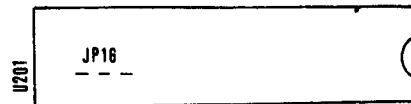
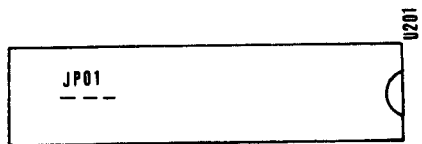

VR202



VR201

FIG. 6-1

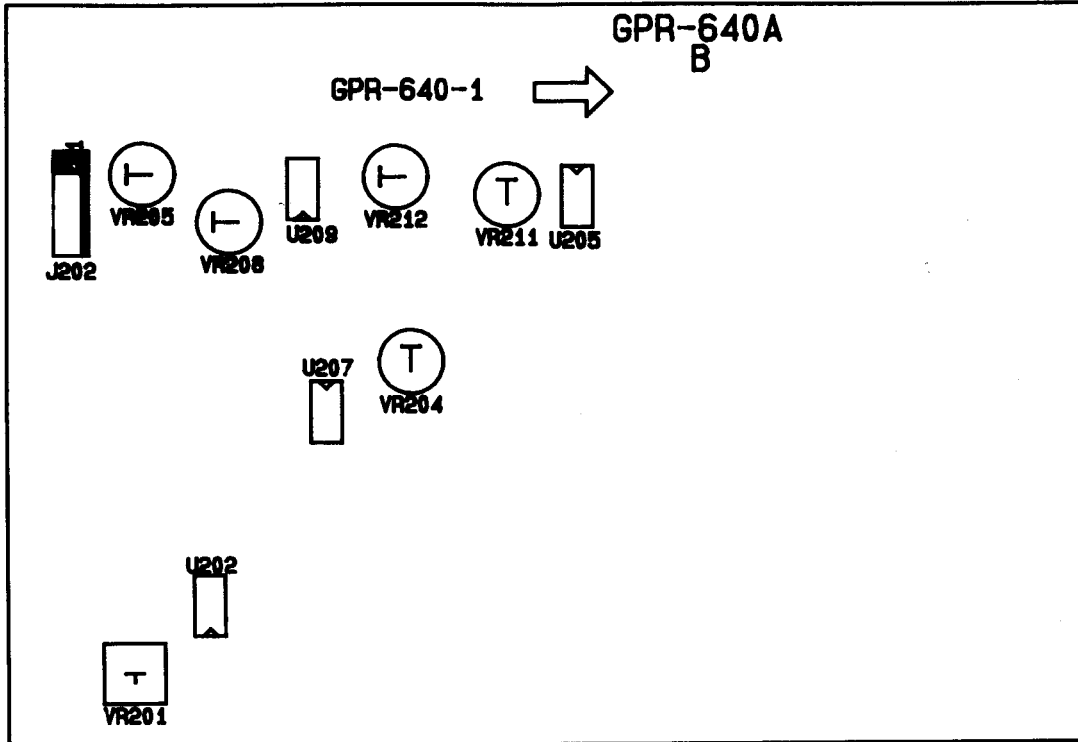
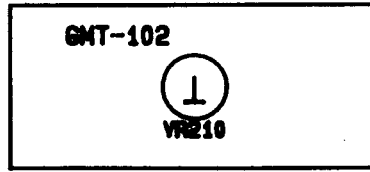
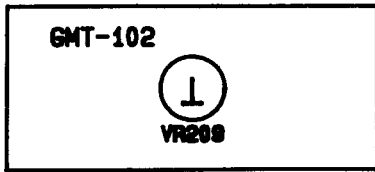

FIG. 6-2

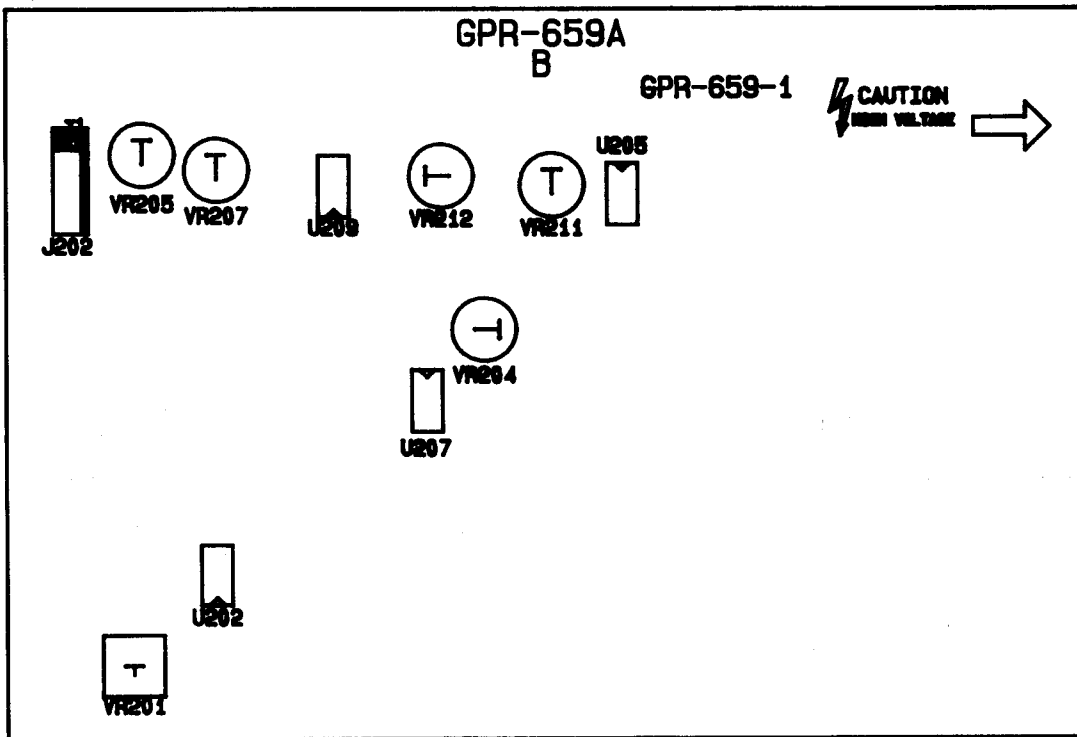
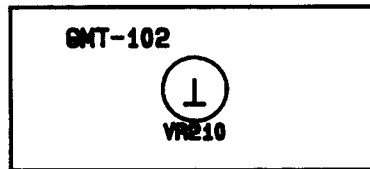
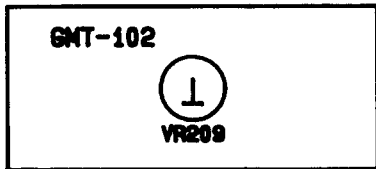

FIG. 6-3

PRECAUTION APPENDIX

The Selection of Output Test Lead and Feedback Test Lead:

For safety assurance, please select the adequate output test lead according to the following list:

UL (CSA) Model	Conductor				Maximum Conductive Resistor Ω/km	Permissible Current A(amp)
	Wire No. AWG	Component pc/mm	Cross Section Area (mm^2)	Outer Diameter mm		
1015 TEW (Twisted Wire)	24	11/0.16	0.22	0.64	88.6	7.64
	22	17/0.16	0.34	0.78	62.5	10.0
	20	21/0.18	0.53	0.95	39.5	13.1
	18	34/0.18	0.87	1.21	24.4	17.2
	16	26/0.254	1.32	1.53	15.6	22.6
	14	41/0.254	2.08	2.03	9.90	30.4
	12	65/0.254	3.29	2.35	6.24	40.6
	10	65/0.32	5.23	3.00	3.90	55.3

Remark:

1. The ambient temperature of "Permissible Current" is at 40°C, the withstanding temperature of conductor is at 105°C according to the condition of the distributed single wire.
2. The permissible current listed as above is suggested to be used under 70%.
3. If the feedback test leads are in need, the level above UL(CSA) AWG24, 22, 20... can be accepted. Besides, when the load is a capacitive load, please use the twine wire by twisting (+)output test lead with (S+) feedback test lead. Same way used on (-) output test lead and (S-) feedback test lead.
4. When the current value exceeds above suggestive list, can select more wires used in parallel according to above list.